

3.02 Specifications

Filling capacity	max. 7,000 kg/h (15,400 lbs/h)
Filling pressure	max. 20 bar (300 PSI)
Pump gear revolutions	130 rpm
Portion size range	5-30,000 g
Portioning speed	max. 400 portions/min.
Compensation	for 1st portion
Twists per portion	up to 10
Vacuum pump suction capacity	25 m ³ /h (20 cfm)
Connected load	11 kW
Hopper (standard)	300 l (660 lbs)
Weight depending on model	≈ 1,410 kg (3,100 lbs)

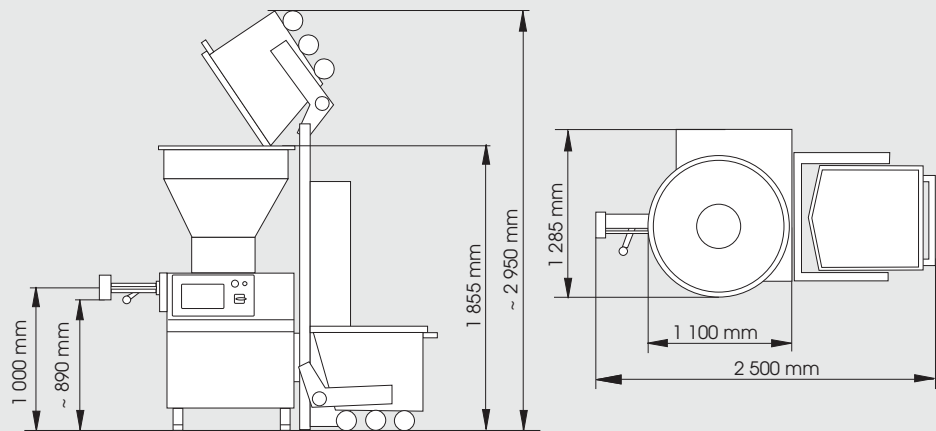

We reserve the right to make technical changes without prior notice.

3.03 Noise Emission

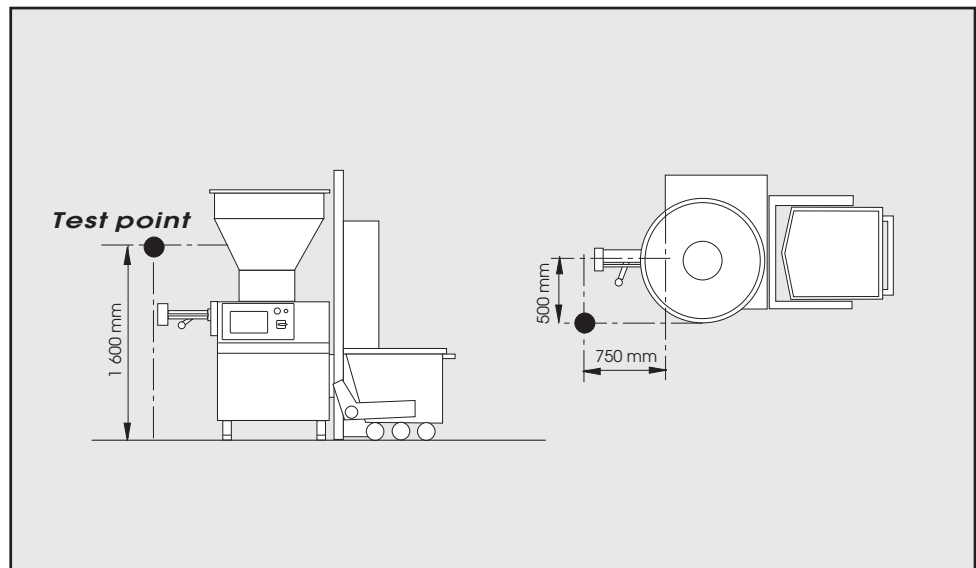

Noise measurement for straight stuffing without twisting with 100% filling speed without product with sound level meter (DIN 45 634) < 80 dB(A)

Noise measurement with twisting with 100% filling speed < 80 dB(A)