

INDUSTRIAL CUTTERS

ELABORATE CONCEPT ENHANCING YOUR PRODUCTIVITY

K 200
K 330

K 500
K 750



APPLICATIONS OF THE LASKA CUTTERS

The LASKA cutter technology is based on practical research and development work as well as long years of experience. Combined with other machines, the LASKA cutter is suitable for large quantities to be processed, but also for smaller batches. Both fresh meat and pre-chopped frozen meat can be processed, and rind emulsions can be produced without any difficulty. Customers use the LASKA cutters to produce:

- › Raw sausage
- › Cooked sausage
- › Scalded sausage
- › Rind emulsion
- › Pies
- › Preserved products
- › Soups and sauces
- › Sweets
- And much more ...

STRENGTHS AND BENEFITS

The cutting effect of the LASKA cutter has been continuously improved in the past few years by optimizing speed, the shape of the knives, and the cutting chamber. This has had a special impact on the stability of the sausage meat, on machine cleaning, and on cutting set maintenance. Featuring high cutting rates and a special cutting geometry, the LASKA cutter ensures a consistently smooth and cohesive product in a short time.

QUALITY PROVEN IN USE

Just like all other LASKA machines, the cutters are made of solid stainless materials. They meet strict hygienic requirements and are easy to clean. The design allows for the unusual operating conditions and provides easy and safe operating options as well as good access for servicing.



THE LASKA CUTTER

YOUR BENEFITS AT A GLANCE

HYGIENE AND SAFETY

- › Sealing keeps area between bowl and vacuum jacket free from product residues
- › Closed Base plate prevents soiling of the machine interior
- › Knife hood swinging open wide, therefore best accessibility for knife change and cleaning
- › Higher rim of cutter bowl minimizes product leakage
- › Polished surfaces for highest possible hygienic standard
- › Safety equipment for optimum working safety

PRODUCTION

- › High hourly output
- › Excellent cutting quality
- › Infinitely variable knife shaft speed and bowl speed
- › Synchronous running of knife speed and bowl speed additionally possible
- › Mixing cycle in reverse for gentle mixing in
- › Speed of unloader infinitely variable, suitable for all kinds of emulsion

SERVICE AND MAINTENANCE

- › Easily exchangeable knives
- › Low-wear special sealing
- › Central lubricating point - micro-processor-controlled automatic lubrication on request
- › Minimum maintenance required due to field-tested machine concept
- › Easily accessible inspection doors
- › Worldwide service network and competent advice on all continents

DESIGN

- › Compact design with integral control box (optionally also external)
- › Cutter bowl with reliable true running accuracy and large diameter of the slewing ring bearing (min. 650 mm)
- › Bowl gear motor with soft start and automatic switching down
- › No bending stress on knife shaft, since the bearing is located exactly in the axis of the belt force
- › Long service life
- › Low operating noise
- › Attractive, elegant design
- › Economical LED interior light

ELECTRICAL EQUIPMENT

- › Low current consumption due to state-of-the-art drive and control technology
- › Programmable logic controller with microprocessors
- › Temperature display

OPERATION

- › Easy handling and user-friendly, robust operating elements
- › Control panel with membrane keyboard and plain text display - with touch screen on request
- › Infinitely variable unloader disc speed for perfect unloading
- › 4 (optionally 8) infinitely variable and freely selectable speeds of the knife shaft for perfect product adaptation
- › Large and easily accessible feed opening



EQUIPMENT FOR YOUR LASKA CUTTER



MODERN DRIVE TECHNOLOGY

- › Compact, hygienic design due to integral control box
- › Highly efficient state-of-the-art components
- › Infinitely variable drive
- › Low-maintenance AC three-phase motor
- › Automatic soft start and switch back for jerk-free change of speed minimizes stress on bearings and drive

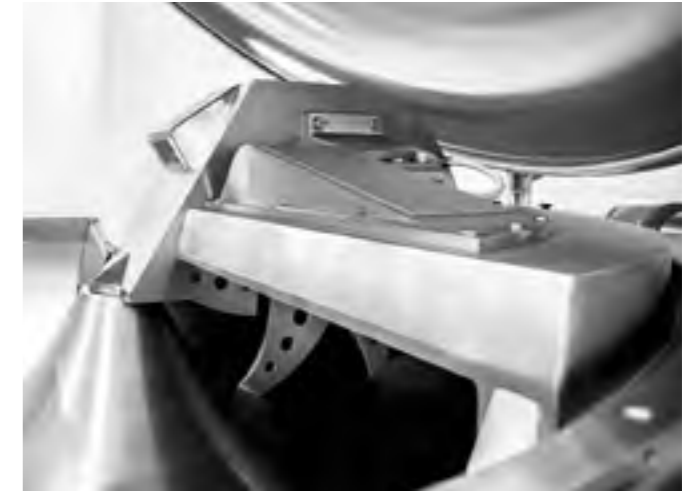

KNIFE SHAFT

- › Specially developed bearing technology and sealing for highest speeds and high operating safety
- › Low-wear special sealing
- › No bending stress on knife shaft
- › Long service life of bearings and sealing



KNIFE HEAD

- › Standardized knife length
- › The knives can be inserted in any mounting position and in any LASKA SuperCutter Plus of the same size
- › Improved hygienic conditions and corrosion resistance
- › Cost-efficient and easy to maintain



KNIFE HEAD INSTALLATION AND DISMANTLING

- › Magnetic fixing and identical knife length permit easy exchange of knives
- › Knife exchange without dismantling of knife head possible

EQUIPMENT FOR YOUR LASKA CUTTER



CUTTER BOWL

- › Solid, stainless cast steel with high true running accuracy
- › Cutter bowl ball bearing with extraordinarily large diameter (650 - 850 mm)
- › Special sealing between bowl and vacuum jacket (at option with vacuum)



KNIFE HOOD SEALING

- › Special spring-loaded sealing to cutter bowl prevents leakage of sausage meat
- › Removable for easy cleaning



CENTRAL LUBRICATING POINT

- › Perfect access
- › Easy handling
- › Micro process controlled central lubricating system for automatic lubrication (optional)



FILTER SYSTEM

- › Filtered air is supplied direct to the motor and the control box, thus reducing the dust load
- › Optimized routing of cooling air flow of main motor with filter system and monitoring unit for cooling
- › Overpressure in machine interior prevents the penetration of dust via small gaps and increases cooling capacity



KNIFE HOOD

- › Product-variable knife hood with removable baffle plate
- › Optimized form permits maximum fineness of the products at short batch times and a regular cut
- › Solid, double-walled structure



HYDRAULIC UNLOADER

- › Infinitely variable speed of unloader disc for perfect unloading
- › Optional unloader discs for raw sausage and/or highly fluid products



ELECTRONIC EQUIPMENT

- › Compact, hygienic design due to built-in control box that can be swivelled out to ensure perfect access for maintenance
- › With remote maintenance as an option



JOYSTICK

- › Blind operation
- › Hygienic design

KNIFE SHAPES

OPTIMUM CUTTING SET ACCORDING TO THE CUSTOMER'S REQUIREMENTS



UNIVERSAL KNIFE LC

- › For scalded sausage, cooked sausage, raw sausage
- › Stable, cohesive, and homogeneous sausage meat with high protein yield
- › High fineness
- › Unequalled edge-holding property due to high-strength, tough, stainless special steel grades



SPECIAL KNIFE LCT

- › Extra-fine emulsions
- › Rind processing
- › Unequalled edge-holding property due to high-strength, tough, stainless special steel grades



SPECIAL KNIFE LCTH

- › Extra-fine emulsions
- › Rind processing and cooked products
- › Unequalled edge-holding property due to high-strength, tough, stainless special steel grades



SPECIAL KNIFE LCR

- › For raw sausage
- › Excellent cut and even granulation
- › Unequalled edge-holding property due to high-strength, tough, stainless special steel grades



OPTIONS FOR YOUR LASKA CUTTER

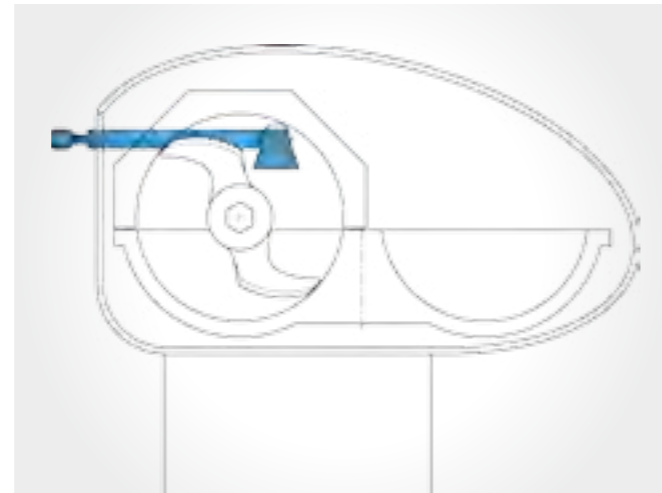

VACUUM VERSION

- › Improved quality and taste as well as longer shelf life of scalded sausage products
- › Time, duration, and degree of vacuum freely selectable as a function of the product and the operating mode
- › Entrapped air is minimized
- › Clear cut and intensive, even reddening
- › Flavour is kept
- › Smaller volume of sausage meat means less casing required

NITROGEN COOLING

- › Standardized and automated sausage production ensuring consistent quality
- › Fresh colour and longer shelf life of finished products
- › Optimum and quick temperature distribution during the production process
- › Particularly gentle cooling without freezer burn
- › Clear cut of meat and fat in case of raw sausage production

WATER DOSING

- › Automatic addition of a freely selectable amount of water during the production process
- › Adding can be interrupted any time during automatic water addition
- › Desired amount of water is selected at the control panel / touch screen and can be called up any time
- › For various liquids such as milk, oils, additives, etc.

CLEANING TROLLEY

- › For better cleaning of knives and flanges
- › Hygienic and space-saving
- › Safe handling of knives
- › For 2 sets of knives and 8 patented rings

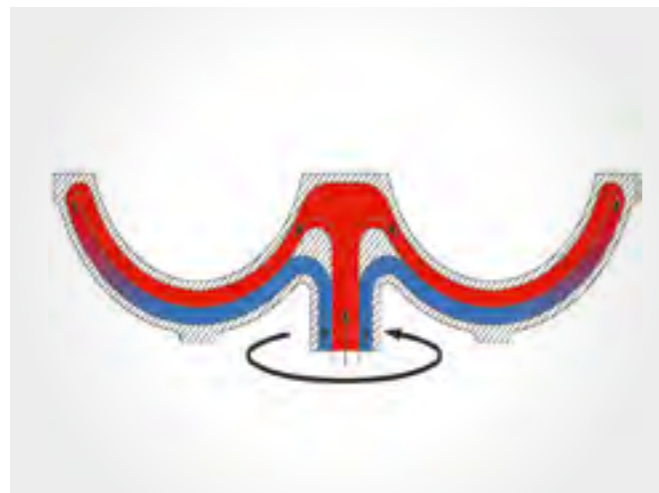

COOKING FACILITY

- › Production of cooked sausage and pies in one process
- › Improved quality due to intense taste
- › Short process times and optimum efficiency factor
- › No undesired dilution due to closed circuit of heating and cooling media
- › Including automatic temperature control and stainless noise reduction lid

FORCED VENTILATION

- › In case of extreme dust load
- › Dissipates heat from air-conditioned production chamber
- › Basic version of forced ventilation: supply and exhaust air flange for connection to external fans
- › Full version of forced ventilation: supply and exhaust air flange with 6 linear metre stainless vent pipes (250 mm Ø), each, 3 manifolds and a supply air fan with air filter (for protection class IP 65)

HYDRAULIC LOADING FOR 200 LITRE STANDARD TRANSPORT TROLLEY

- › Easy to operate
- › Stainless, hydraulic
- › Robust, low-maintenance, and durable due to hydraulic drive
- › Two loading facilities are possible for type K 750
- › High tilt angle

KNIFE BALANCING DEVICE

- › Easy balancing of knife head units
- › Avoids unbalance and vibrations

PMS PRODUCTION MANAGEMENT SYSTEM



PMS MINI

- › Up to 30 recipes of 100 process steps, each
- › Recipes are editable
- › Membrane keyboard panel
- › Programme recording via teach-in process



PMS MIDI

- › Up to 99 recipes of 100 process steps, each
- › Up to 20 daily production lists
- › Touch screen
- › Programme recording via teach-in process or programmable on touch screen
- › Including USB interface

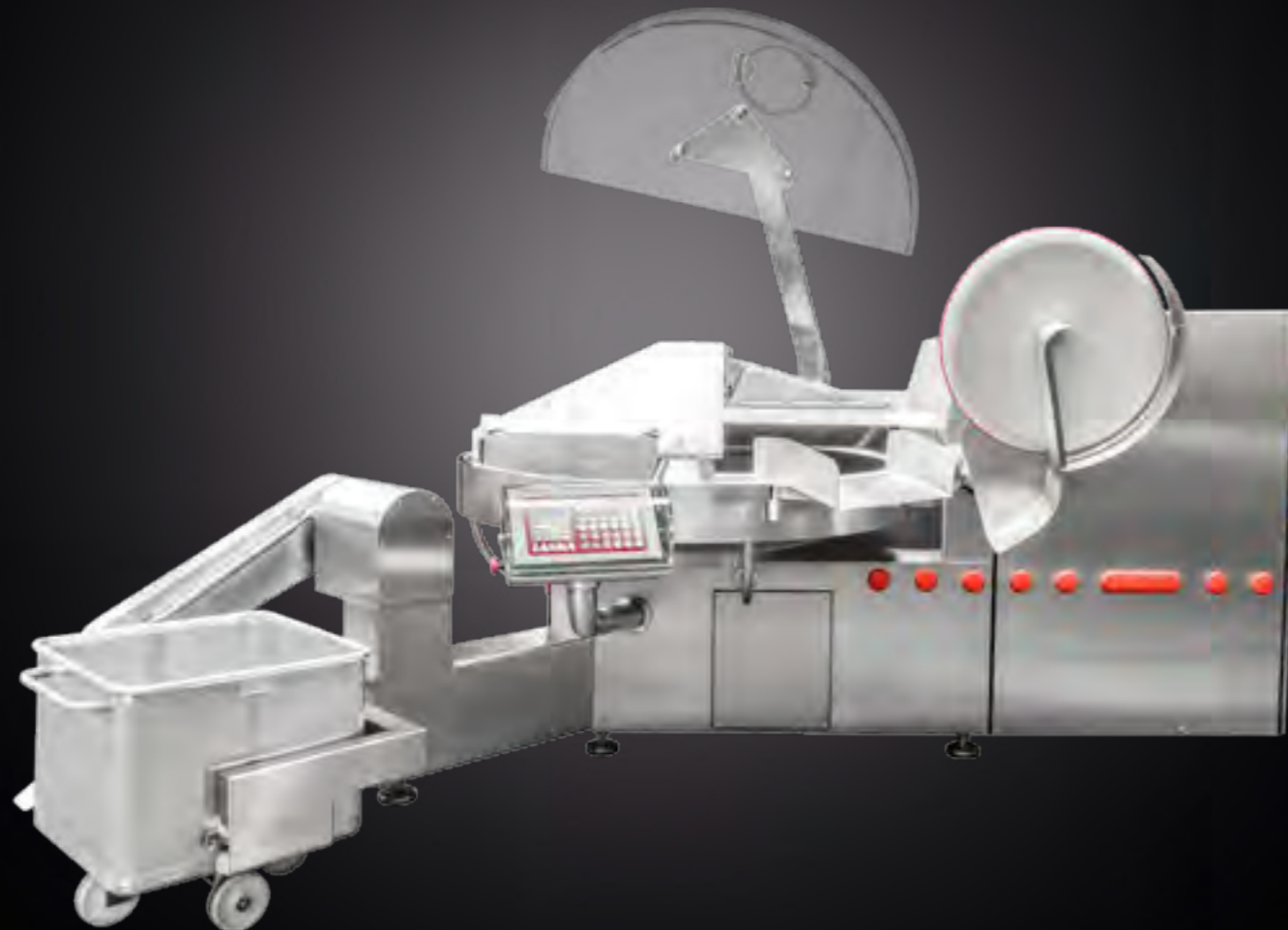

PMS MAXI

- › Up to 999 recipes of 999 process steps, each
- › Up to 20 daily production lists
- › Touch screen
- › Programme recording via teach-in process or programmable on touch screen or PC
- › Creation and editing of daily production lists on PC



TRACEABILITY

Midi and Maxi

- › Process data storage for recording of all process steps and for documentation
- › Data output via USB interface (Midi) and/or external PC (Maxi)
- › Direct further use of data in all ©Windows programmes

THAT'S WHAT OUR CUSTOMERS SAY ABOUT THEIR LASKA GRINDER



GOTZINGER SMALLGOODS
AUSTRALIA

"From my earliest days in the meat processing industry. I was introduced to LASKA Meat Machinery. My Father used LASKA Cutters and Miners throughout his career, and when I had the opportunity to purchase my first Bowl Cutter and Mixer/Mincer for my own business, it had to be LASKA. So for over Thirty Years, I have been supported by the highest quality machinery in the industry. I have seen some excellent advancements in sausage production in my time, and LASKA has always been at the forefront of developing reliable, hygienic and efficient equipment.

It is a common knowledge, that to produce the best products, you must have the best equipment. And with LASKA, I have that confidence."

MR. VAN DER DRIFT
OWNER



**WIESBAUER - ÖSTERREICHISCHE
WURSTSPEZIALITÄTEN GMBH**
AUSTRIA

"In LASKA we have found a long-standing and reliable partner offering a comprehensive range of machinery. We highly appreciate the quick assistance we get.

What convinced us was the in particular powerful mixing cycle of the cutter. Older cutter models, too, proved their worth in the past, which led to our purchasing the new cutters. We are very pleased with the performance of LASKA and the cutters. We'd make the same decision again."

MR. SPECHT
PRODUCTION MANAGER



**ISANA NATURFEINKOST GMBH & CO.
PRODUKTIONS UND HANDELS KG**
GERMANY

"Our LASKA Super Cutter KV 330 has become an indispensable item in our daily production processes. We have been able to achieve important progress for product quality and efficiency in the production of humus, pesto and various different sauces thanks to this machine.

The ease of operation plus the all-round Laska service round off our sense of satisfaction with this investment perfectly."

MR. LUTZ
MANAGING DIRECTOR



TECHNICAL DATA

PERFORMANCE LIST

PERFORMANCE CHARACTERISTICS						
TYPE			K 200	K 330	K 500	K 750
Bowl volume	ltr		200	330	500	750
Motor rating	kW	KU KUX	104 113	142 150	172 182	250 270
Fuse	A		250	400	500	630
Feed pipe cross section	mm ² CU		120	240	240	300
Speed knife shaft max.	rpm	KU KUX	4600 5800	3900 4800	3600 4200	3000 3300
Speed mixing cycle max.	rpm		230	195	180	150
Bowl speed	rpm		2 - 16	2 - 16	2 - 16	2 - 16
Unloader disc speed	rpm		70 - 140	70 - 140	70 - 140	60 - 120
Vacuum version			o	o	o	o
Suction capacity vacuum pump	m ³ /h		160	250	250	400
Cooking facility			o	o	o	o
Cooling facility			o	o	o	o
Forced ventilation			o	o	o	o
Water dosing			o	o	o	o
Internal control box			•	•	•	-
External rol box			o	o	o	•
Balancing device			o	o	o	o
Touch screen			o	o	o	o
Loading			o	o	o	o

CAPTION

- standard
- o option

DIMENSIONS AND WEIGHT					
TYPE		K 200	K 330	K 500	K 750
Length mm X		3600	4000	4170	4550
Width mm Y		3060	3100	3280	3800
Height mm Z		1650	1850	1860	2020
Height incl. lid mm A		2550	2850	2850	3020
Weight kg		4250	5550	6000	8000

SEAWORTHY CASE*					
Length mm		3900	4300	4470	4850
Width mm		2330	2330	2330	2330
Height mm		2400	2400	2400	2400
Weight kg		750	850	1000	1200

* depending on type of transport

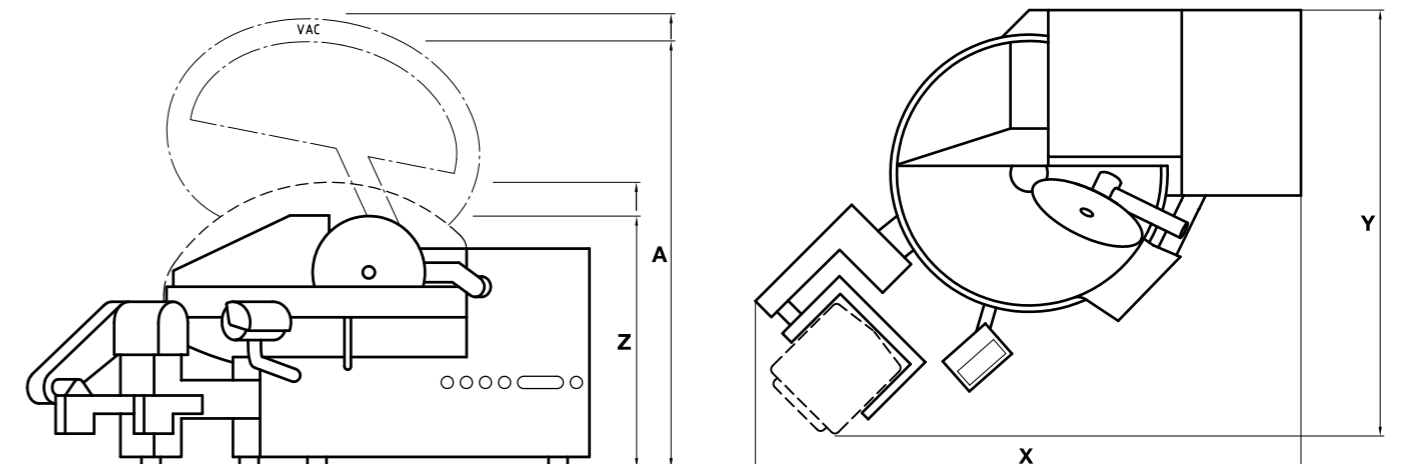

TRADITION & INNOVATION

MORE THAN 130 YEARS OF EXPERIENCE



We have more than 130 years experience of supporting our customers in the production of first-class food.

LASKA develops and manufactures high-quality specialist machinery that has always enjoyed a reputation for durability and reliability. Our experts work with our customers to develop innovative solutions for the finest meat-processing systems. Our robust and capable machines have proven their worth in a range of other application areas as well.

LASKA is a family company with a global reach; our customers are using our machines successfully in more than 140 countries on every continent in the world.

OUR PRODUCT RANGE:

- Cutters
- Grinders
- Frozen meat cutters
- Emulsifiers
- Mixers
- Production lines



Maschinenfabrik LASKA Gesellschaft m.b.H.

Makartstraße 60, 4050 Traun – Austria

P +43 7229 / 606-0

F +43 7229 / 606-400

laska@laska.at

www.laska.at

DEALER/PARTNER

